



TBR-1500 W

MAGNETIC MECHANICAL INTERPHASE BRACKET SYSTEM

Item No. 30051

Introduction

The TBR-1500 W is a non-penetrating, non-destructive magnetic bracket system designed to provide a mechanical interphase between a ferrous steel surface and the product being installed.

Engineered for rapid deployment and secure mounting, it enables installations to be completed quickly, safely, and without surface damage.

Its wide interface features multiple pre-drilled holes, offering flexibility for a broad range of mounting configurations. The system is built using two **V-MAG 340® magnets** and thruster feet, ensuring stable attachment and safe removal - even on painted or coated surfaces.

Key Features

- **Non-Invasive Installation**
No drilling, welding, or permanent modifications required.
- **Flexible Mounting Options**
Multi-hole interface supports diverse product configurations.
- **Strong Magnetic Attachment**
Utilizes **2 x V-MAG 340® magnets** for robust holding power.
- **Safe Handling**
Equipped with thruster feet for easy and safe mounting/demounting.
- **Ideal for Temporary or Permanent Use**
Suitable for applications where both stability and reversibility are critical.

The **TBR-1500 W** is the ideal solution for mounting equipment, enclosures, or structural components in sectors where speed, adaptability, and preservation of surface integrity are essential.

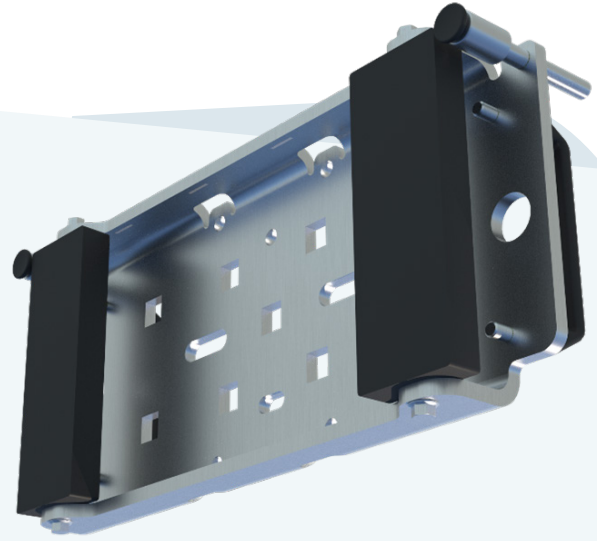
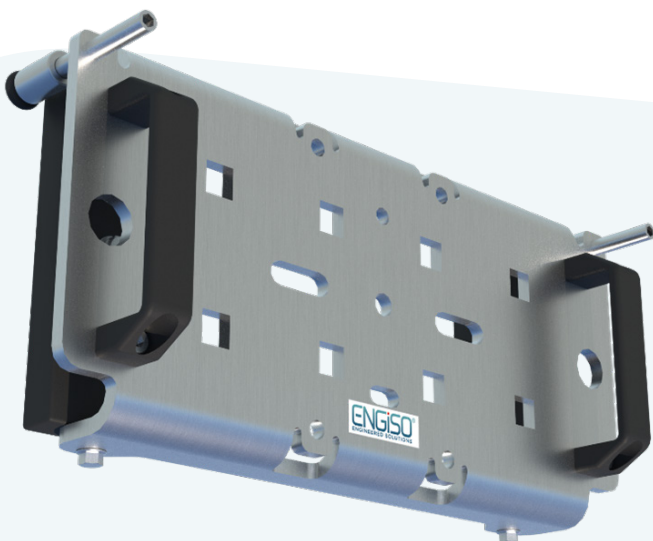



Technical specifications

-  **Weight:** 4,8kg
-  **Length:** 400mm
Width: 205mm
Height: 100mm
-  **Diameter:** 2000mm (minimum diameter needed for curved/convex surfaces)
-  **Thickness:** 6mm (optimal ferrous steel thickness)
-  **Temp.:** -40°C to +80°C (operating)
-  **Material:** Aluminum (seawater resistant)
-  **Load Test:** V-MAG 340© (Load test witnessed by DNV-GL)
-  **Strength:** 680kg (Breaking strength by direct pull from clean steel)
-  **Suitability:** V-MAG 340©

Contact us

If you would like a free quotation or learn more about how **TBR-1500 W** can optimize your workflow and finances - feel free to contact us.

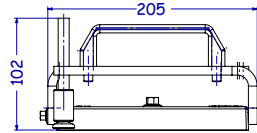

Item No. 30051

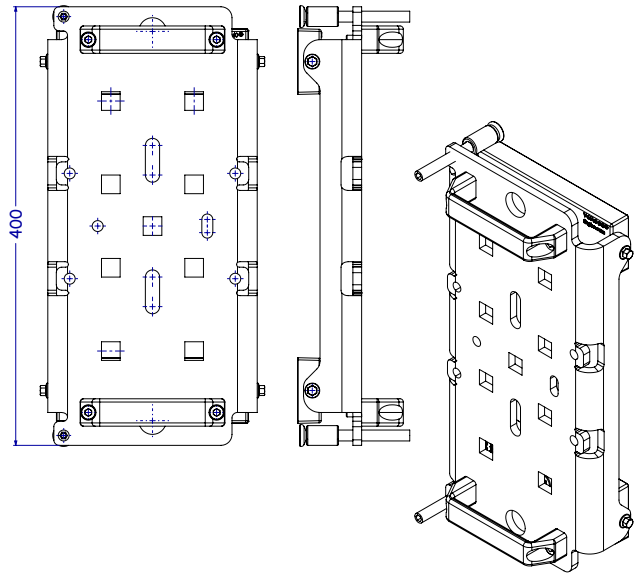

Installation steps

